

© 1970 BY AMP INCORPORATED. ALL RIGHTS RESERVED. AMP PRODUCTS COVERED BY PATENTS AND/OR PATENTS PENDING. REPRODUCED WITHOUT WRITTEN PERMISSION OF AMP INCORPORATED.

REVISIONS				
ZONE	DATE	DESCRIPTION	DATE	APPROVED
O		NP570-0113 (REV2) + 70-0829 (REV1) <i>Final</i>	12-8-70	FCY
A		REVISED PER ECN F-5575	6-17-71	FCY
B		REV PER ECN R-5575	7-11-72	JML
C		REVISED PER ECN F-598	10-26-72	JML
D		REVISED G+3026 4-30-73	4-12-88	GY
E				JML
F		REV 70-0113-004-48	2-5-79	JML TT
G		REV PER OG3A-0801-00	11/06/00	JR/TM

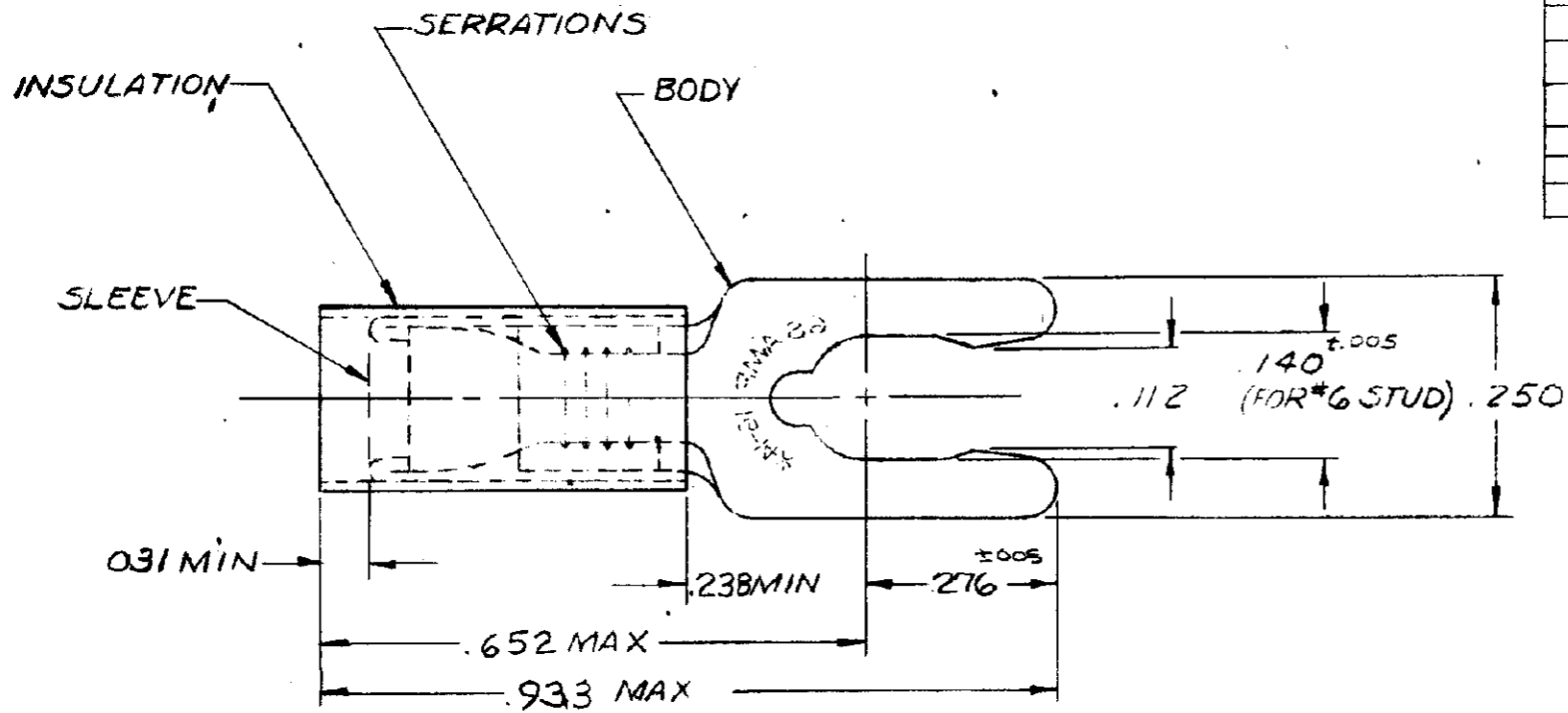

FOR WIRE INS. DIA (SEE TABLE II)
TONGUE MATERIAL THK .031 ±.002

TABLE II

PART NO	PART NO ON TAPE	WIRE INS. DIA
9-52420-1		.115-.170
8-52420-1		.105-.150
52420-1	52420-3	.115-.170
52420	52420-2	.105-.150

1	WIRE TERMINAL	SEE TABLE II	INSULATION: NYLON COLOR: BLUE SLEEVE: COPPER (ASTM B 152) TIN PL (ASTM B 545) BODY: PHOSPHOR BRONZE (ASTM B 139) TIN PL (ASTM B 545)	
QTY	DESCRIPTION	PART NO.	MATERIAL & FINISH	
UNLESS OTHERWISE SPECIFIED DIMENSIONS ARE IN INCHES - TOLERANCES: DECIMALS ±.008 ANGLES ± 5°		CONTRACT NO. *	 AMP INCORPORATED HARRISBURG, PENNSYLVANIA	
MATERIAL		DR. <i>J. M. Enaminger</i> 12-5-70 CHK. <i>W. Youngblood</i> 12-8-70 APPD. <i>Swab</i> 12-10-70 REL. <i>Hyman</i> 12-19-70		NAME: WIRE TERMINAL P.I.D.G.-SPRING SPADE WIRE SIZE: 16-14
SEE TABLE I		OSCN APPD		SIZE: B COLE IDENT NO.: 00779 NUMBER: 52420
		OTHER APPD		SCALE: NTS SHEET: 1 OF 1